



CHRISTY LIGHTING LTD
NO 8 NORTHUMBERLAND COURT
DUKES PARK INDUSTRIAL ESTATE
CHELMSFORD
ESSEX CM2 6UW
01245-451212 FAX 01245-451818.



sports industry traffic shopping public

ULTRA LOW GLARE FLOODLIGHTING

HORIZONTAL GLASS SYSTEM

OPTIONAL ULTRA LOW GLARE BAFFLE .

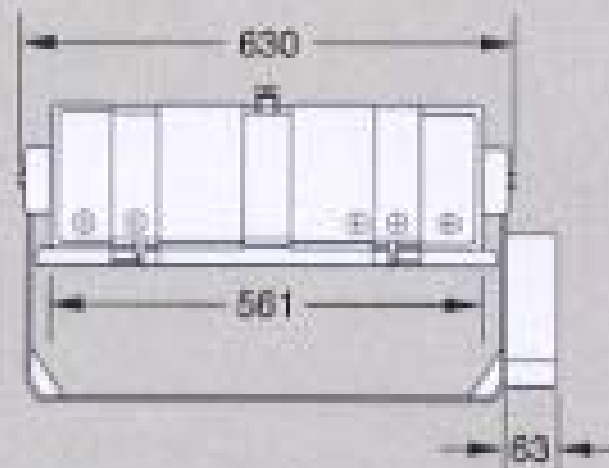
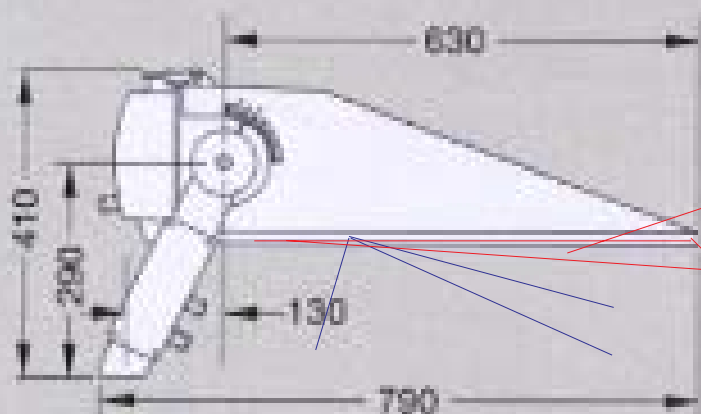

$A_w = 0.23 \text{ m}^2$
 $G_{max} = 21 \text{ kg}$ (mit Normalzündung)
 $G_{max} = 25 \text{ kg}$ (mit Zündgerät für sofortige
Heißwiederzündung)

Maße in mm





CHRISTY LIGHTING LTD
NO 8 NORTHUMBERLAND COURT
DUKES PARK INDUSTRIAL ESTATE
CHELMSFORD
ESSEX CM2 6UW
01245-451212 FAX 01245-451818.

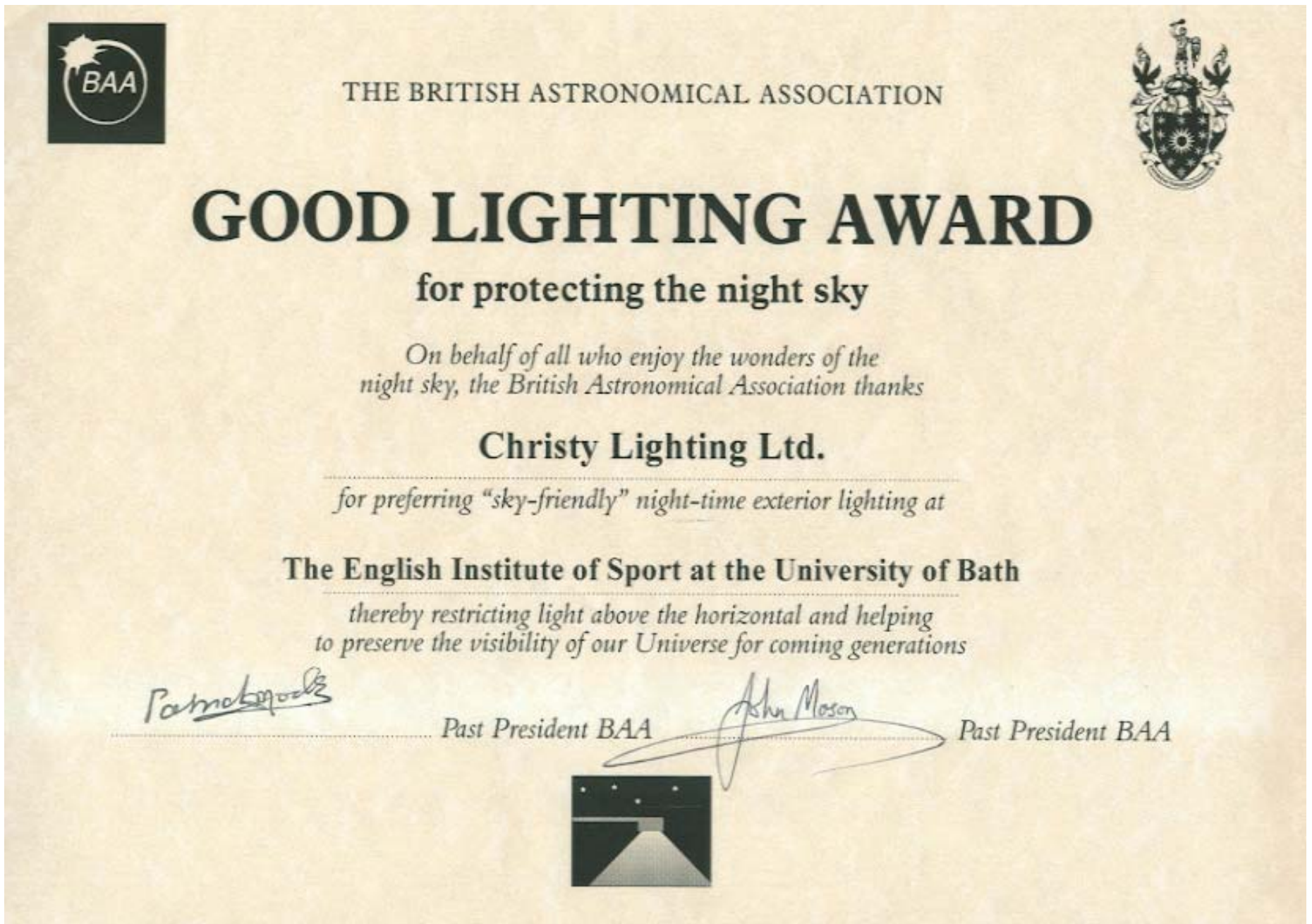

Siemens-Siteco c/w Christy-Siteco 2225 baffle



Champion 3272 Adjustable Beam & Optional baffle





CHRISTY LIGHTING LTD
 NO 8 NORTHUMBERLAND COURT
 DUKES PARK INDUSTRIAL ESTATE
 CHELMSFORD
 ESSEX CM2 6UW
 01245-451212 FAX 01245-451818.

15	50																
0	5	10	15	20	25	30	35	40	45								
50	55	60	65	70													
-90	-85	-80	-75	-70	-65	-60	-55	-50	-45								
-40	-35	-30	-25	-20	-15	-10	-9	-8	-7								
-6	-5	-4	-3	-2	-1	0	1	2	3								
4	5	6	7	8	9	10	15	20	25								
30	35	40	45	50	55	60	65	70	75								
00	0	0	0	0	0	0	0	0	0	0	0	0	0	0	0-90°		
0	0	0	0	0	0	0	0	0	0	0	0	0	0	0	0		
00	0	0	0	0	0	0	0	0	0	0	0	0	0	0	0-80°		
0	0	0	0	0	0	0	0	0	0	0	0	0	0	0	0		
000	00	0	0	0	0	0	0	0	0	0	0	0	0	0	0-70°		
0	0	0	0	0	0	0	0	0	0	0	0	0	0	0	0		
00	0	0	0	0	0	0	0	0	0	0	0	0	0	0	0-60°		
0	0	0	0	0	0	0	0	0	0	0	0	0	0	0	0		
00	00	0	0	0	0	0	0	0	0	0	0	0	0	0	0-50°		
0	0	0	0	0	0	0	0	0	0	0	0	0	0	0	0		
000	0	0	0	0	0	0	0	0	0	0	0	0	0	0	0-40°		
0	0	0	0	0	0	0	0	0	0	0	0	0	0	0	0		
000	00	0	0	0	0	0	0	0	0	0	0	0	0	0	0-30°		
00	0	0	0	0	0	0	0	0	0	0	0	0	0	0	0		
000001	0001	0001	0001	0001	0000	0000	0000	0000	0000	0000	0000	0000	0000	0000	0-20°		
006	008	005	004	004	002	005	03	02	01	01	01	01	01	0	0		
0348	0334	0283	0251	0181	0154	0103	0110	0075	0041	0013	0002	0001	0000	0000	0-10°		
560	509	452	377	243	189	171	150	114	045	14	02	1	0	0	0-9°		
772	685	621	503	306	225	239	190	153	050	016	02	01	1	0	0-8°		
902	831	754	710	356	268	295	237	191	050	16	02	1	0	0	0-7°		
1032	977	888	641	407	309	352	284	230	051	17	02	1	1	1	0-6°		
1064	1082	0972	0696	0481	0381	0400	0347	0273	0066	0018	0002	0001	0000	0000	0-5°		
1097	1188	1056	751	555	452	448	410	317	081	020	02	1	1	1	0-4°		
1085	1239	1098	836	643	554	493	470	364	097	020	02	1	1	1	0-3°		
1106	1260	1133	928	742	641	534	525	424	112	020	02	1	1	1	0-2°		
1170	1248	1144	991	815	722	578	569	480	122	022	02	1	1	1	0-1°		
0001229	1250	1141	1021	0864	0764	0621	0607	0536	0124	0024	0002	0001	0001	0001	0-0°		
1191	1222	1143	1103	917	835	713	503	565	123	025	02	1	1	1	0-1°		
1219	1254	1279	1235	1070	807	730	632	534	123	027	03	1	1	1	0-2°		
1191	1216	1233	1250	1120	994	805	600	550	127	023	02	1	1	1	0-3°		
1114	1155	1147	1144	1081	982	814	700	610	150	026	03	2	1	1	0-4°		
01069	1120	1130	1082	1059	0911	0798	0722	0596	0202	0025	0003	0002	0001	0001	0-5°		
1024	1086	1114	1020	1037	841	783	745	581	256	024	003	02	01	01	0-6°		
0998	1032	1062	1037	1020	923	766	723	538	213	024	003	02	1	1	0-7°		
973	0978	1011	1057	1004	1005	751	701	495	170	024	03	2	1	1	0-8°		
977	980	1048	1168	1140	1060	807	708	530	235	039	03	2	1	1	0-9°		
000980	00982	1085	1280	1278	1118	0856	0717	0565	0300	0061	0003	0002	0001	0001	0-10°		
0544	0566	0654	0679	655	648	571	560	459	180	077	04	02	1	1	0-15°		
0364	0364	0377	0397	0426	0388	0336	0285	0276	0121	0074	0008	0002	0002	0002	0-20°		
303	306	292	291	285	269	249	207	215	093	75	22	02	2	2	0-25°		
0216	0246	0216	188	0186	0200	0193	0184	0162	0087	0077	0038	0003	0002	0002	0-30°		
316	338	341	312	281	276	258	229	174	101	79	45	03	2	2	0-35°		
0419	430	0466	0437	0377	0353	0324	0275	0186	0115	0081	0053	0003	0002	0002	0-40°		
320	330	355	346	317	293	267	232	177	116	78	58	03	2	2	0-45°		
0221	0231	0245	0256	0258	0233	0211	0189	0164	0118	0076	0064	0003	0002	0002	0-50°		
170	176	187	191	194	177	159	156	142	106	74	54	02	2	2	0-55°		
0120	0122	0129	0127	0130	0122	0107	0123	0120	0093	0073	0044	0002	0002	0002	0-60°		
077	078	082	082	80	77	64	70	68	53	42	23	01	1	1	0-65°		
032	035	037	038	035	031	022	020	018	13	12	06	1	1	1	0-70°		
00	00	00	00	00	00	00	00	00	00	00	00	00	00	00	0-75°		
0	0	0	0	0	0	0	0	0	0	0	0	0	0	0	0-80°		

2223-lamp1-Position-1 INTENSITY TABLE FOR CLMF/SNA 758-0-1WB2 FLOODLIGHT-SITECO
 2000W OSRAM HQI-TS LAMP- Low Glare -2001 production-Low Glare Optics 31-10-2000
 measured by Siteco 3-7-2001.



HORIZONTAL ILLUMINANCE VALUES

Y/X .0 10.0 20.0 30.0 40.0 50.0 60.0 70.0 80.0 90.0 100.0 110.0 120.0 130.0 140.0 150.0 160.0 170.0 180.0

.0 0.0 0.0 0.0 0.0 .1 .2 .2 .2 .2 .2 .2 .1 0.0 0.0 0.0 0.0 0.0 0.0

10.0 0.0 0.0 0.0 .1 .2 .5 .4 .4 .4 .4 .5 .2 .1 0.0 0.0 0.0 0.0 0.0

20.0 0.0 0.0 .1 .2 .3 1.3 1.1 1.3 1.2 1.3 1.1 1.3 .3 .2 .1 0.0 0.0 0.0 0.0

30.0 0.0 .1 .2 .3 1.1 3.7 3.7 3.5 3.4 3.5 3.7 1.1 .3 .2 .1 0.0 0.0 0.0 0.0

40.0 0.0 .1 .3 .7 3.2 10.0 13.9 16.2 14.4 16.2 13.9 10.0 3.2 .7 .3 .1 0.0 0.0 0.0 0.0

50.0 0.0 .1 .4 3.4 18.0 49.6 64.4 66.4 79.7 66.4 64.4 49.6 3.4 .4 .1 0.0 0.0 0.0 0.0

60.0 0.0 .1 .5 12.8 75.4 191.1 154.9 156.5 190.9 156.5 154.9 191.1 75.4 12.8 .5 .1 0.0 0.0 0.0 0.0

70.0 0.0 .1 .5 21.9 33.8 213.5 211.7 219.5 239.8 219.5 211.7 213.5 33.8 4.9 .5 .1 0.0 0.0 0.0 0.0

80.0 .1 .1 .4 8.4 63.1 139.8 243.3 240.6 221.0 240.6 243.3 139.8 63.1 8.4 .4 .1 0.0 0.0 0.0 0.0

90.0 .1 .1 .3 9.5 91.7 317.9 224.9 267.4 213.9 267.4 224.9 317.9 91.7 9.5 .3 .1 .1 0.0 0.0 0.0

100.0 .1 .1 .4 8.6 72.9 263.3 276.1 221.9 221.4 221.9 276.1 263.3 72.9 8.6 .4 .1 .1 0.0 0.0 0.0

110.0 0.0 .1 .2 2.2 116.8 223.3 238.1 286.4 297.8 286.4 238.1 223.3 116.8 2.2 .2 .1 0.0 0.0 0.0 0.0

120.0 .1 .1 .4 8.6 72.9 263.3 276.1 221.9 221.4 221.9 276.1 263.3 72.9 8.6 .4 .1 0.0 0.0 0.0 0.0

130.0 .1 .1 .3 9.5 91.7 317.9 224.9 267.4 213.9 267.4 224.9 317.9 91.7 9.5 .3 .1 0.0 0.0 0.0 0.0

140.0 .1 .1 .4 8.4 63.1 139.8 243.3 240.6 221.0 240.6 243.3 139.8 63.1 8.4 .4 .1 .1 0.0 0.0 0.0

150.0 .1 .5 4.9 33.8 213.5 211.7 219.5 239.8 219.5 211.7 213.5 33.8 4.9 .5 .1 0.0 0.0 0.0 0.0

160.0 .1 .5 12.8 75.4 191.1 154.9 156.5 190.9 156.5 154.9 191.1 75.4 12.8 .5 .1 0.0 0.0 0.0 0.0

170.0 0.0 .1 .4 3.4 18.0 49.6 64.4 66.4 79.7 66.4 64.4 49.6 18.0 3.4 .4 .1 0.0 0.0 0.0 0.0

180.0 0.0 .1 .3 .7 3.2 10.0 13.9 16.2 14.4 16.2 13.9 10.0 3.2 .7 .3 .1 0.0 0.0 0.0 0.0

190.0 0.0 .1 .2 .3 1.1 3.7 3.7 3.5 3.4 3.5 3.7 3.7 1.1 .3 .2 .1 0.0 0.0 0.0 0.0

200.0 0.0 0.0 .1 .2 .3 1.3 1.1 1.3 1.2 1.3 1.1 1.3 .3 .2 .1 0.0 0.0 0.0 0.0 0.0

210.0 0.0 0.0 0.0 .1 .2 .5 .4 .4 .4 .4 .5 .2 .1 0.0 0.0 0.0 0.0 0.0 0.0

220.0 0.0 0.0 0.0 0.0 .1 .2 .2 .2 .2 .2 .2 .2 .1 0.0 0.0 0.0 0.0 0.0 0.0

RESULTS FOR THE SUB GRID RUN Grid dimensions in metres

Maximum Illuminance.....	317.908
Minimum Illuminance.....	139.811
Average Illuminance.....	225.155
Diversity (Min/Max).....	.440
Uniformity (Min/Avg).....	.621
Utilisation Factor.....	.415

Grass Training Pitch



Brankin Road Stables

FUTURE ACCESS ROADWAY

FIRTH M...



CHRISTY LIGHTING LTD
NO 8 NORTHUMBERLAND COURT
DUKES PARK INDUSTRIAL ESTATE
CHELMSFORD
ESSEX CM2 6UW
01245-451212 FAX 01245-451818.

6° Slope Pitches

Multi purpose surface
Training Pitch /
Car Parking (Relief)

Multi purpose surface
Training Pitch /
Car Parking (Relief)

Landing Pond

ILLUMINANCE NORMAL TO TV CAMERA

Y/X .0 10.0 20.0 30.0 40.0 50.0 60.0 70.0 80.0 90.0 100.0 110.0 120.0 130.0 140.0 150.0 160.0 170.0 180.0



CHRISTY LIGHTING LTD
NO 8 NORTHUMBERLAND COURT
DUKES PARK INDUSTRIAL ESTATE
CHELMSFORD
ESSEX CM2 6UW
01245-451212 FAX 01245-451818.

Environmental Zone E.1 = not Exceeding 2 Lux Vertical.
Environmental Zone E.2 = not Exceeding 5 Lux Vertical.

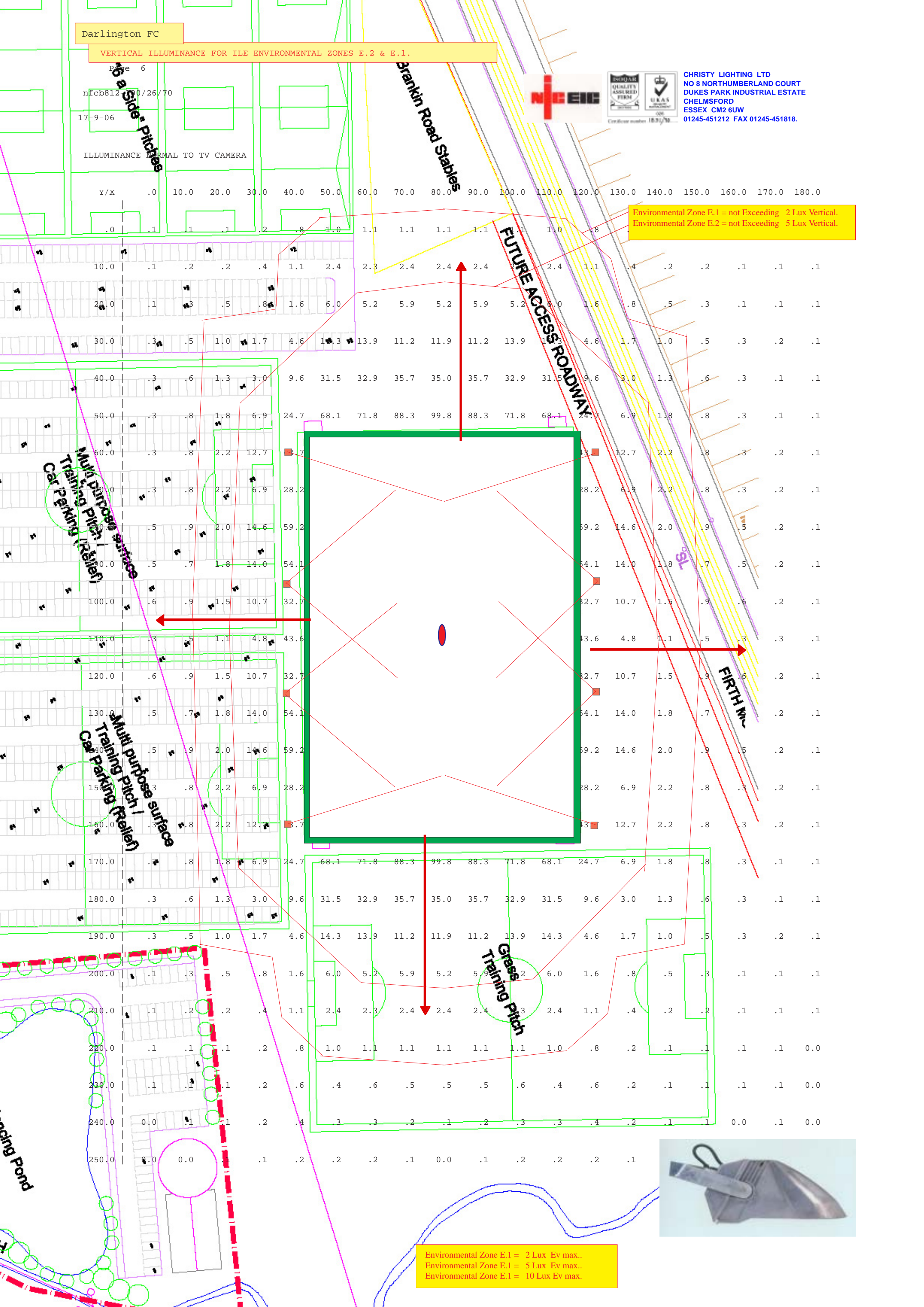

Environmental Zone E.1 = 2 Lux Ev max.
Environmental Zone E.1 = 5 Lux Ev max.
Environmental Zone E.1 = 10 Lux Ev max.





CHRISTY LIGHTING LTD
 NO 8 NORTHUMBERLAND COURT
 DUKES PARK INDUSTRIAL ESTATE
 CHELMSFORD
 ESSEX CM2 6UW
 01245-451212 FAX 01245-451818.

nfc812-100/26/70

17-9-06

FLOOD No	FLOODLIGHT LOCATION			AIMING DETAILS				TOTAL DATA	
	X	Y	H	ELEV	HORZ	X	Y	FILE	FLUX
1	44.5	60.0	15.5	67.7	159.9	80.0	73.0	220.0	3272
2	44.5	60.0	15.5	69.2	150.6	80.0	80.0	.0	3272
3	44.5	60.0	15.5	68.5	130.4	70.0	90.0	.0	2223
4	44.5	96.0	15.5	66.9	225.6	70.0	70.0	210.0	2223
5	44.5	97.0	15.5	66.4	181.6	80.0	96.0	.0	3272
6	44.5	98.0	15.5	65.3	139.2	70.0	120.0	220.0	3272
7	44.5	122.0	15.5	65.3	220.8	70.0	100.0	220.0	3272
8	44.5	123.0	15.5	66.4	178.4	80.0	124.0	.0	3272
9	44.5	124.0	15.5	66.9	134.4	70.0	150.0	210.0	2223
10	44.5	160.0	15.5	68.5	229.6	70.0	130.0	.0	2223
11	44.5	160.0	15.5	69.2	209.4	80.0	140.0	.0	3272
12	44.5	160.0	15.5	67.7	200.1	80.0	147.0	220.0	3272
13	115.5	60.0	15.5	67.7	20.1	80.0	73.0	220.0	3272
14	115.5	60.0	15.5	69.2	29.4	80.0	80.0	.0	3272
15	115.5	60.0	15.5	68.5	49.6	90.0	90.0	.0	2223
16	115.5	96.0	15.5	66.9	314.4	90.0	70.0	210.0	2223
17	115.5	97.0	15.5	66.4	358.4	80.0	96.0	.0	3272
18	115.5	98.0	15.5	65.3	40.8	90.0	120.0	220.0	3272
19	115.5	122.0	15.5	65.3	319.2	90.0	100.0	220.0	3272
20	115.5	123.0	15.5	66.4	1.6	80.0	124.0	.0	3272
21	115.5	124.0	15.5	66.9	45.6	90.0	150.0	210.0	2223
22	115.5	160.0	15.5	68.5	310.4	90.0	130.0	.0	2223
23	115.5	160.0	15.5	69.2	330.6	80.0	140.0	.0	3272
24	115.5	160.0	15.5	67.7	339.9	80.0	147.0	220.0	3272

Television camera position.

X co-ordinate= 80.000

Y co-ordinate= 110.000

Height = .100





CHRISTY LIGHTING LTD
NO 8 NORTHUMBERLAND COURT
DUKES PARK INDUSTRIAL ESTATE
CHELMSFORD
ESSEX CM2 6UW
01245-451212 FAX 01245-451818.

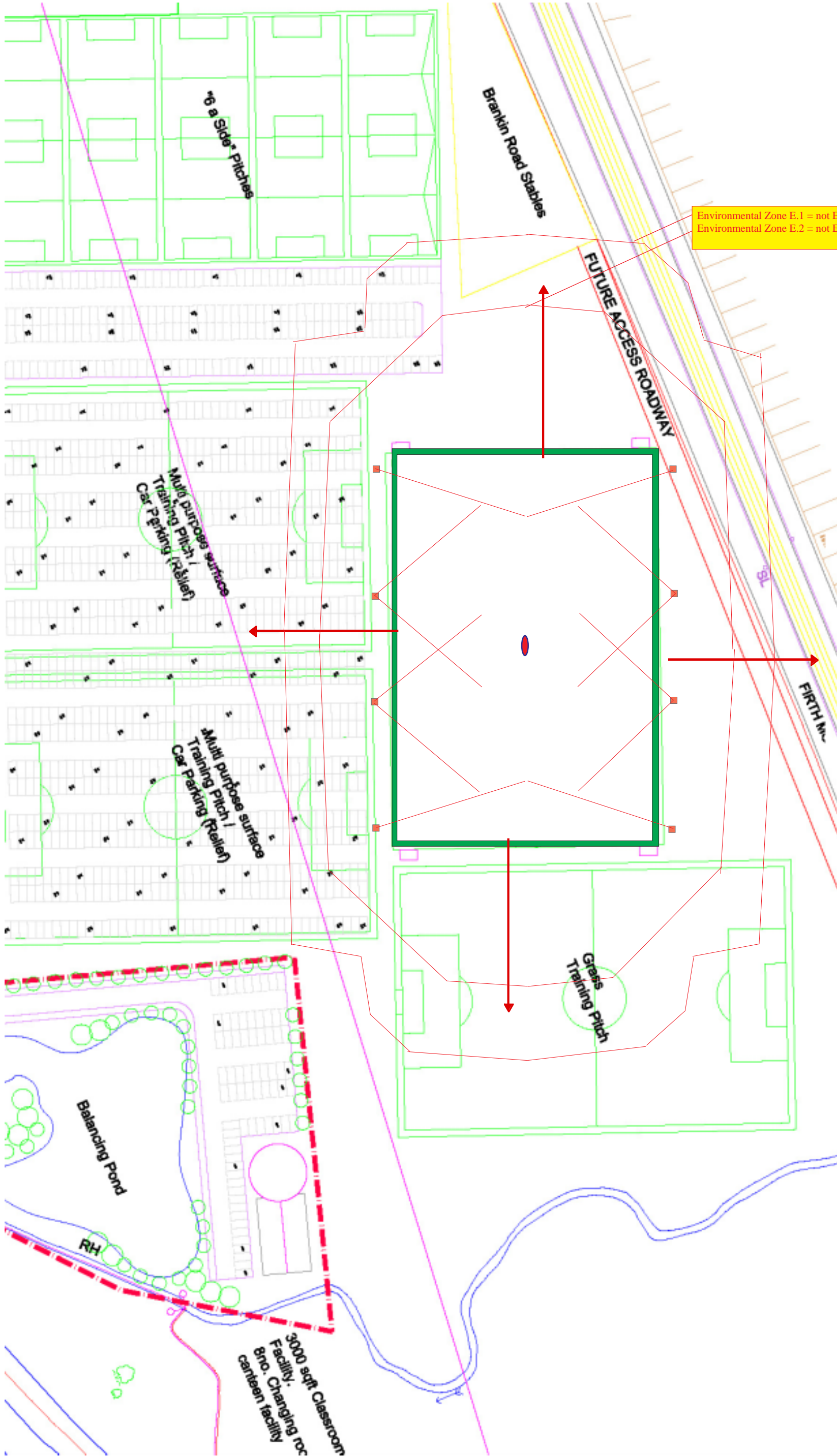

Environmental Zone E.1 = not Exceeding 2 Lux Vertical.
Environmental Zone E.2 = not Exceeding 5 Lux Vertical.



CHRISTY LIGHTING LTD
NO 8 NORTHUMBERLAND COURT
DUKES PARK INDUSTRIAL ESTATE
CHELMSFORD
ESSEX CM2 6UW
01245-451212 FAX 01245-451818.

Ultra Low Glare Floodlighting system for Suffolk County Council

